

Z07/...

Mat.: 1.7131/580 + 40 HV 30

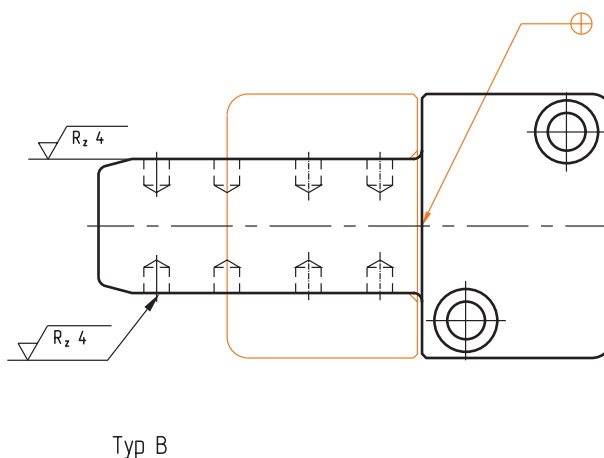
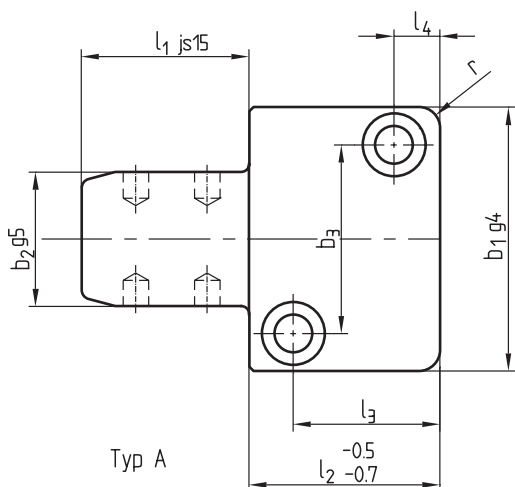
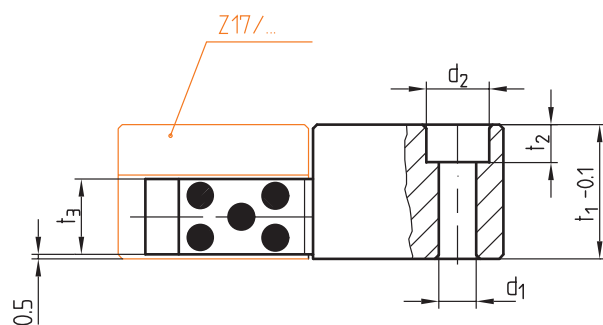

Typ	max. °C	r	t <sub>3</sub>	t <sub>2</sub>	t <sub>1</sub>	d <sub>2</sub>	d <sub>1</sub>	l <sub>4</sub>	l <sub>3</sub>	b <sub>3</sub>	b <sub>1</sub>	l <sub>2</sub>	b <sub>2</sub>	l <sub>1</sub>	Nr./No.
A	200	6	11	6,8	20	11	6,6	7	15	26	40	<b>22</b>	<b>16</b>	<b>20</b>	Z07/22/16x 20
B														<b>40</b>	40
A			13		22				19	31	45	<b>27</b>	<b>20</b>	<b>25</b>	Z07/27/20x 25
B														<b>50</b>	50
A		8	14		25			9	27	35	50	<b>36</b>	<b>25</b>	<b>32</b>	Z07/36/25x 32
B														<b>63</b>	63
A			19	9	32	15	9	11	35	45	63	<b>46</b>	<b>32</b>	<b>40</b>	Z07/46/32x 40
B														<b>80</b>	80
A		10	22	11	36	18	11	15	40	60	85	<b>56</b>	<b>40</b>	<b>50</b>	Z07/56/40x 50
B														<b>100</b>	100
A			24	13	40	20	14	18	48	74	100	<b>66</b>	<b>50</b>	<b>56</b>	Z07/66/50x 56
B														<b>112</b>	112

This is trial version  
www.adultpdf.com